

**Exaustor
EQ600M4**

OBS. DESENHOS ILUSTRATIVOS

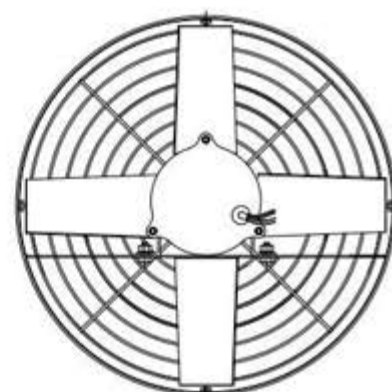
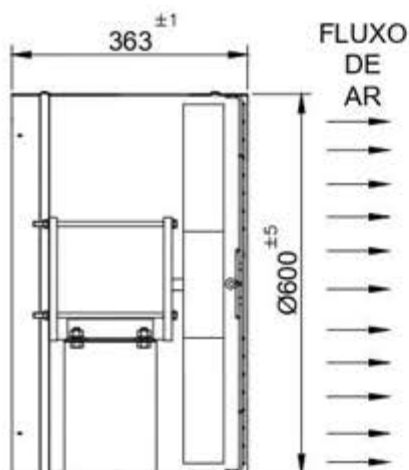

ESQUEMA DE LIGAÇÃO
VIDE PLAQUETA DO MOTOR

CURVA CARACTERÍSTICA
(20°C/760 mm Hg)

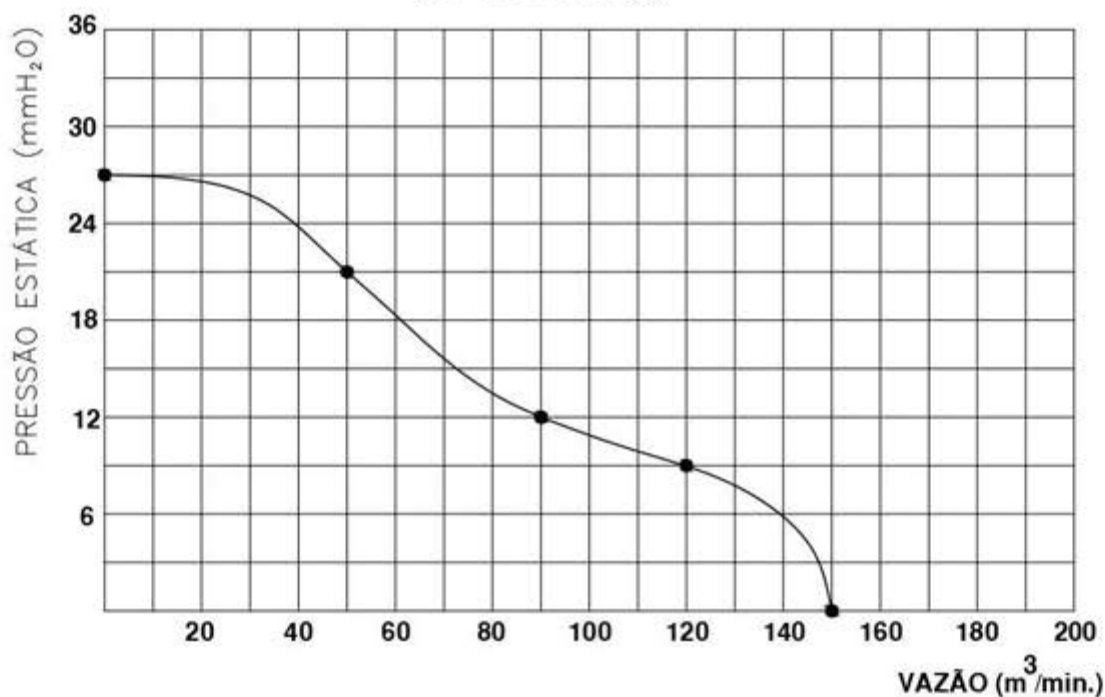

Todos os valores registrados neste folheto estão sujeitos a alterações sob critério do fabricante sem prévio aviso.

CÓPIA NÃO CONTROLADA